



AIR CONDITIONING CONTRACTORS ASSOCIATION OF CENTRAL FLORIDA

SERVING THE ORLANDO AREA

The Hot Flash

Issue No. 2-13 - April/May 2013

In This Issue

Presidents's Message

Designing For Comfort: Selecting Air Distribution Outlets - By David A. John

News From Our Members

The Inspectors Corners

Instructors Needed

Meet The Board

Education Program Notice

Monthly Meeting Schedule

Associate Members

President's Message

As President of ACCA/CF, I want to personally thank our guest speaker, Bob Cochell of Gulf Coast Air Systems, Inc. for an excellent presentation at the March Educational Luncheon. As always, when Bob visits attendance is nearly standing room only and everyone was sure to pay attention. Thank you Bob for the updated information regarding Mechanical & Energy Code Changes and What's Going on with Refrigerant.

And a personal thank you to Rick Dalrymple of Insurance Office of America, the speaker at the April luncheon who spoke on the topic of Best Practices: Keys for Profitability in a New Economy.

Be sure to remember our May Luncheon Meeting May 16, 2013 at Crowne Plaza. The speaker will be Jeff Sonne of Florida Solar Energy Center and the topic will be an EnergyGauge USA Residential Software Demonstration.

Also, on Saturday, April 27th, ACCA/CF will hold its first Road Rally in Altamonte Springs. Be sure to visit our website for more information and join us on this fun filled upcoming event.

Last but certainly not least, thank you to all of our Associate Members for all of your support for ACCA/CF and its Contractor Members. Have a safe and prosperous summer.

Scott Hudson



Selecting Air-Distribution Outlets

Designing for Comfort

By David A. John, P.E., Member ASHRAE

A great deal of time is spent designing a system, including sizing chillers and air handlers and laying out pumps and controls, but how much time is spent selecting air-distribution devices? In conversations with design engineers, they estimate spending weeks and months laying out chillers, air handlers, controls and ductwork, but estimate they spend only minutes selecting and laying out air-distribution devices. Most of the HVAC consulting engineer's time is spent designing a system to meet the required ventilation rate and space temperature, but occupant discomfort can still occur if the space air velocity is too high.

The tendency of designers is to add more air-distribution devices, spaced closely together, as a margin of safety for a project. Using proper air-distribution device selection methods can greatly improve occupant comfort, and reduce the number

of devices. This has the added value of reducing the amount of ductwork required and the associated accessories and labor. These savings can be accomplished by the designer without a significant amount of additional design time.

Cost of Discomfort

A review of existing literature found that the effect of comfort on productivity generally covers ventilation rate and temperature. The literature suggests that the potential annual saving or productivity gain (in 1996 U.S. dollars) can be as much as \$20 to \$160 billion.¹ The financial costs due to reduced productivity associated with occupants' thermal discomfort are significantly greater than the costs due to the much publicized sick building syndrome.

Mixed Air-Distribution System

One factor that is commonly overlooked in an air-distribution system design is the resulting room air velocities



Continued on page 4

Need Portable Cooling?

Call the Specialists

- Primary, Supplemental, or Emergency Cooling
- Rentals & Sales
- Offices Nationwide
- On Call 24/7



 **Atlas Sales & Rentals, Inc.**
THE PORTABLE COOLING & HEATING SPECIALISTS
www.AtlasSales.com

Call:
800.972.6600

MOVINCOOL.
PREFERRED DISTRIBUTOR
MovinCool, SpotCool & Office Pro
are registered trademarks of
DENSO Corp.

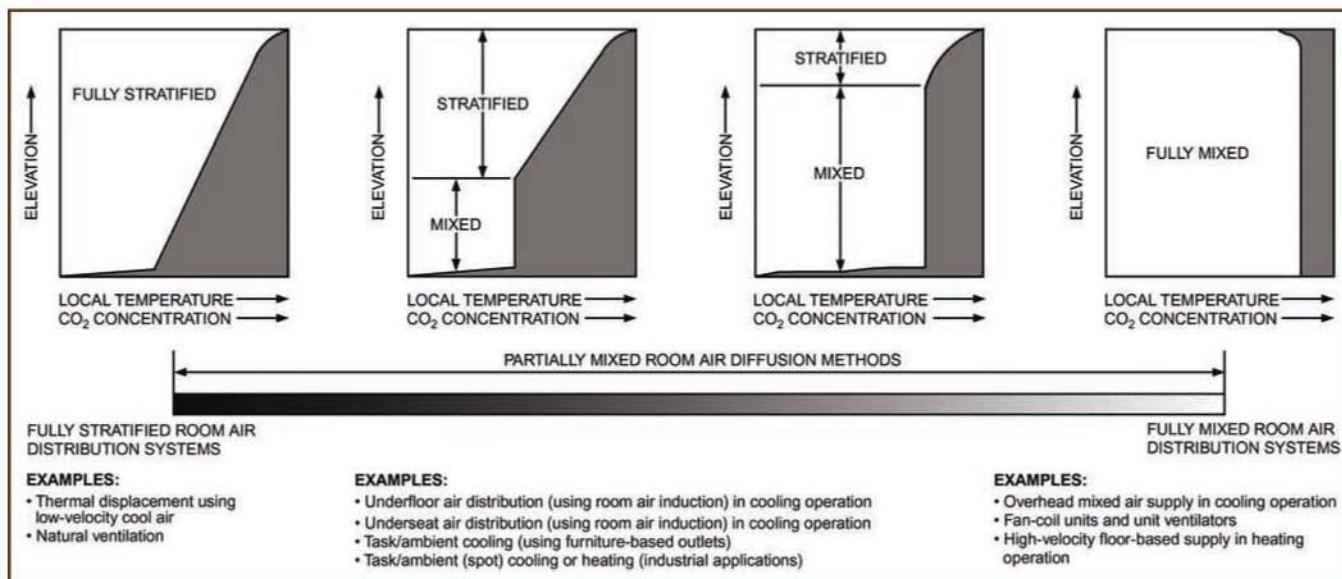

Figure 1: Classification of air-distribution strategies (from 2009 ASHRAE Handbook—Fundamentals).

generated by the outlets and the spacing of the outlets. It is fairly common to see outlets spaced too close together and the downward draft that is generated. Also, it is common to see outlets placed too close to an architectural feature that protrudes below the ceiling, resulting in the horizontal jet being forced down into the space and causing drafts for the occupants.

Several methods described below can be used to avoid high velocity jets and the resulting drafts when selecting outlets for an air-distribution system. These methods can be implemented without adding a significant amount of design time for a project. Designing to control room air motion will lead to higher levels of comfort and a more productive environment.

Defining a Fully Mixed System

ASHRAE Handbook—Fundamentals, Chapter 20, Space Air Diffusion, defines a fully mixed system as the following:

“In mixed-air systems, high-velocity supply jets from air outlets maintain comfort by mixing room air with supply air. This air mixing, heat transfer and resultant velocity reduction should occur outside the occupied zone. Occupant comfort is maintained not directly by motion of air from the outlets, but from secondary air motion that results from mixing in the unoccupied zone. Comfort is maximized when uniform temperature distribution and room air velocities of less than 50 fpm (0.25 m/s) are maintained in the occupied zone.”

A fully mixed system ideally maintains a constant temperature gradient from the floor to the top of the occupied zone. Unlike displacement systems or underfloor systems, the fully mixed system maintains a uniform temperature through dilution of the space air with the air supplied into the space (Figure 1).

Typically, a forced air system is designed to meet the following performance parameters: 73°F to 77°F (23°C to 25°C) with humidity at 25% to 60% and air velocity in the occupied zone of less than 50 fpm (0.25 m/s).

The latest version of ASHRAE Standard 55-2010 allows for elevated air speeds “to be used to increase the maximum operative temperature for acceptability under certain conditions.” These temperatures and velocities are shown in the standard’s Figure 5.2.3.1. This article covers air outlet selection where the desired temperature range is 73°F to 77°F (23°C to 25°C).

Effect of Velocity on Comfort

Figure 2 shows the effect of room air velocity on the perception of comfort. The figure also shows the neck region is more sensitive to air motion than the ankle region. As you can see from the graph, in the neck region, the percentage of complaints are significant at and above 50 fpm (0.25 m/s) velocity. In many cases, the perception of a draft is not because of air temperature, but rather the velocity of air around the occupants. This can be demonstrated by the use of a ceiling fan that is turned on to provide cooling, even though the air being circulated is at room temperature.

Outlet Selection

When designing a fully mixed system for comfort, it is important to define the occupied and unoccupied zone for a space. The occupied zone is the space we live and work in. It is typically the volume from the floor up to a height of 6 ft (1.8 m) and 6 in. to 1 ft (152 mm to 305 mm) from the walls. The occupied zone depends on the specific space and use of that space. We can use the unoccupied zone to deliver all the high velocity supply air and do all the mixing.

The tool that can be used by a designer to predict the location of a discharge jet is listed as “throw” in a manufacturer’s catalog. The current standard for outlet testing is ASHRAE Standard 70-2006 (RA 2011), *Method of Testing the Performance of Air Outlets and Air Inlets*, which defines how throw data is obtained and allows the testing of both isothermal and non-isothermal air. Most of the manufacturer’s throw data is, in fact, isothermal air. The reason for this is the data is easier to obtain and is re-

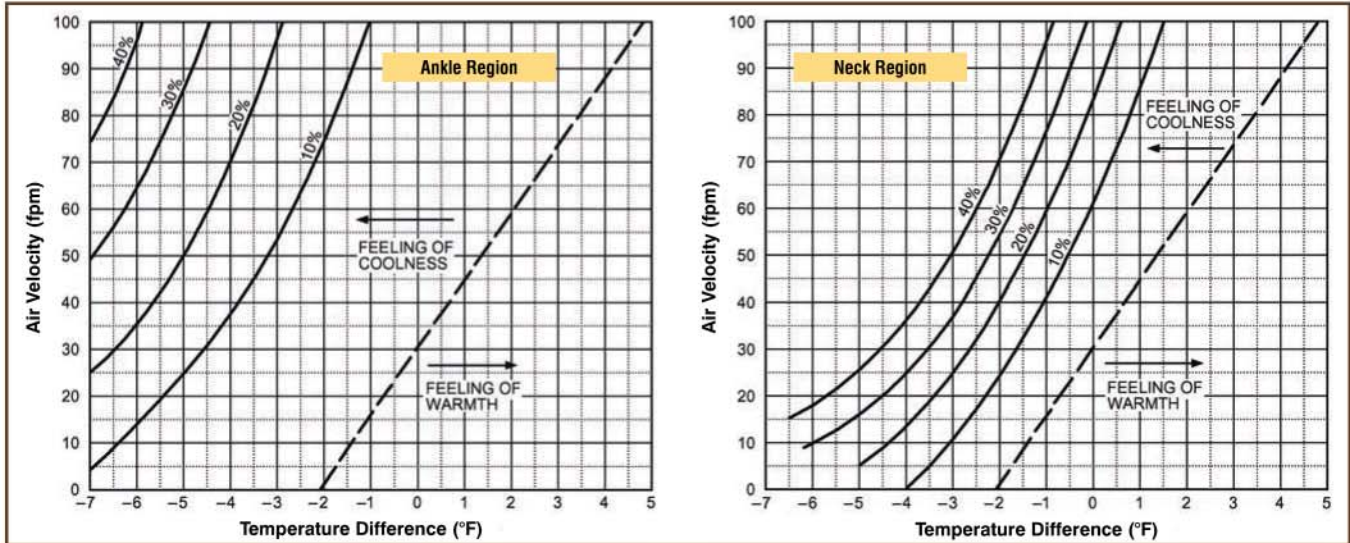

Figure 2: Difference in perception of drafts between the ankle (left) and neck (right) region and percentage of occupants objecting to drafts in air-conditioned rooms (from 2009 ASHRAE Handbook—Fundamentals). Temperature difference is between local temperature and average room temperature.

peatable. Non-isothermal air requires a balanced room, which does require a significant amount of time to conduct testing.

Discharge Jets

Outlets generate a discharge jet. The designer should select the type of outlet and space the outlets so that the maximum velocity in the occupied space does not exceed 50 fpm (0.25 m/s). There are several principles of jet behavior that if used along with the manufacturer’s catalog throw data, the designer can better predict the resulting velocities in the occupied zone.

These principles include:

- A free jet expands at approximately 22°. The expansion of the jet is due to the induction of air around the jet.
- If a jet is directed toward a surface, the jet will want to stay on that surface regardless if the surface is a ceiling, wall or floor.
- At some point, a cooled jet projected along a horizontal ceiling service will separate from the surface and drop downwards. The point where the jet leaves the ceiling is defined as the separation point.

In a mixed air system, the outlet is an “engine” that produces a discharge jet into the unoccupied zone causing air in the occupied zone to be induced into the supply jet. A typical diffuser induces 20 to 30 times the amount of supply air discharged. This rate of induction is how we maintain comfort in a mixed air system. By discharging jets of air into the unoccupied zone, we create air motion and circulation in the occupied zone.

Because of the high rate of induction generated by outlets, the temperature of the supply jet reaches near space temperature within a very short distance from the outlet. Most of the exchange of load from the supply air to the room air occurs within several feet from the outlet.

The outlets should be spaced to ensure that the entire occupied zone has some induction and air motion to avoid stagnant

areas. Placing returns in stagnant areas will not create air motion to pull room air to the return.

Selection by Noise Criteria

The most common method of outlet selection is by using noise criteria (NC) for a device at the required cfm. The designer determines the outlet type and size by using the required cfm for an outlet and the maximum NC levels desired for a space. The NC targeted values most commonly used are from Table 1 of the 2011 ASHRAE Handbook—HVAC Applications, Chapter 48, Noise and Vibration Control (examples of recommended NC values from the Handbook are shown in Table 1).

Although this method will select devices that meet required sound levels, it does not address the primary requirements of maximizing thermal comfort in the occupied zone. Using this method, the diffusers can be spaced too close together creating a draft with a velocity of more than 50 fpm (0.25 m/s) in the occupied zone. This method can also lead to stagnant zones where there is little or no induction from the space into the supply outlet.

Selection Using Throw Data

Using the published throw data obtained from a manufacturer’s catalog is one method of outlet selection that can be used to predict room air velocity. This information will indicate the performance of the discharge jet once it leaves the outlet and can be used to fairly accurately predict resulting space velocities (Figures 3a and 3b).

Throw data obtained per ASHRAE Standard 70-2006 is typically given in a manufacturer’s catalog at 50, 100 and 150 fpm (0.25, 0.51 and 0.76 m/s) (Figure 4). Throw is defined as the distance, in ft (m), from the center of the outlet perpendicular to a point in the mixed airstream where the velocity has been reduced to a specified terminal velocity. In most cases, throw data is based on isothermal air. If either cooled or heated air is

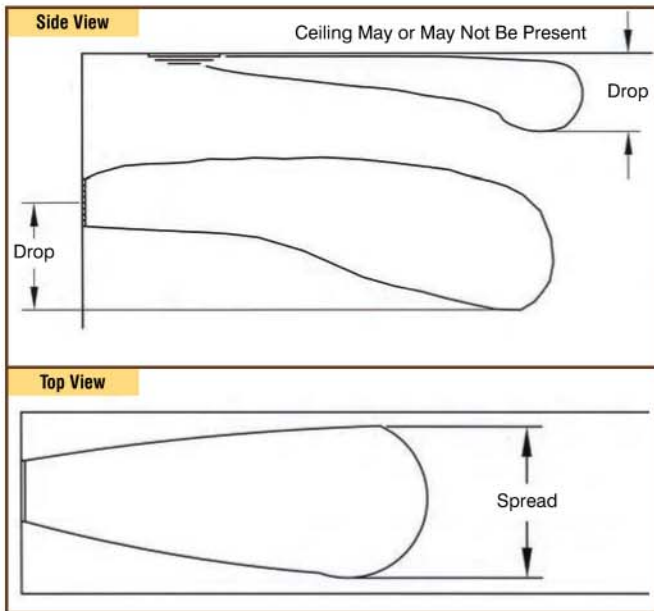

Figure 3a (top): Airstream drop distance. **Figure 3b (bottom):** Airstream spread (from ASHRAE Standard 70-2006 (RA 2011), *Method of Testing the Performance of Air Outlets and Air*).

shown, the throw data does not indicate the drop or rise of the jet or the spread of the jet. Using the throw information, a designer can map out the location of outlets so as to predict and maintain velocity in the occupied zone below 50 fpm (0.25 m/s).

Selection by T_{50}/L and ADPI

Another available method to predict air velocities and comfort in the occupied zone is by using the T_{50}/L ratio to predict the resulting ADPI value for a space where T_{50} is the cataloged throw data to 50 fpm and L is the characteristic length of the space being evaluated. Characteristic Length L is the horizontal distance from the outlet to the outside of the zone the outlet serves. If the outlet is placed so that there are differing distances from the outlet out to the zones served (i.e. a four way pattern), the outlet may have up to four different L values that are used to calculate the T_{50}/L ratio in each direction. Characteristic Length L is defined in Table 3 in Chapter 57 of the 2011 ASHRAE Handbook—HVAC Applications.

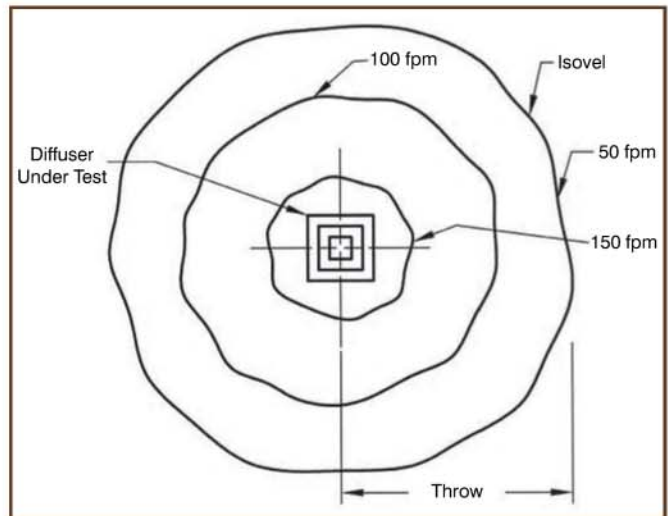

Figure 4: Plan view of ceiling-mounted outlet indicating location of 150, 100 and 50 fpm isovels (from ASHRAE Standard 70-2006).

What is ADPI

Air diffusion performance index (ADPI) is a single number that quantifies the overall comfort of a space when in cooling. ADPI is the percentage of points in a space where the effective draft temperature is between -3°F and $+2^{\circ}\text{F}$ (-19°C and -17°C) and the air velocity is less than 70 fpm (0.36 m/s). A high percentage of people have been found to be comfortable in cooling applications for office-type occupations where these conditions are met. High ADPI values generally correlate to high space thermal comfort levels with the maximum obtainable value of 100.

The effective draft temperature provides a quantifiable indication of comfort at a discrete point in a space by combining the physiological effects of air temperature and air motion on a human body.

A point is considered comfortable if the results of Equation 1 are between -3°F and $+2^{\circ}\text{F}$ (-19°C and -17°C), and the measured velocity at the point is less than 70 fpm (0.36 m/s).

$$T_{ed} = (T_x - T_c) - 0.07(V_x - 30) \quad (1)$$

where

T_{ed} = effective draft temperature, $^{\circ}\text{F}$

T_x = local airstream dry-bulb temperature, $^{\circ}\text{F}$

Room Types		NC/RC	dBA	dBC
Rooms with Intrusion from Outdoor Noise Sources	Traffic Noise	N/A	45	70
	Aircraft Flyovers	N/A	45	70
Residences, Apartments, Condominiums	Living Areas	30	35	60
	Bathrooms, Kitchens, Utility Rooms	35	40	60
Hotels/Motels	Individual Rooms or Suites	30	35	60
	Meeting/Banquet Rooms	30	35	60
	Corridors and Lobbies	40	45	65
Office Buildings	Service/Support Areas	40	45	65
	Executive and Private Offices	30	35	60
	Conference Rooms	30	35	60
	Teleconference Rooms	25	30	55
	Open-Plan Offices	40	45	65
	Corridors and Lobbies	40	45	65

Table 1: Examples of recommended NC values (from 2011 ASHRAE Handbook—HVAC Applications).

T_c = average (control) room dry-bulb temperature, °F

V_x = local airstream centerline velocity, fpm

By determining the value of T_{50} from a manufacturer's catalog, and measuring the characteristic length L from the project's plans, the ratio can be determined and the predicted ADPI value can be estimated from *Table 2*.

Location of Return/Exhaust Grilles

ASHRAE Handbook—HVAC Applications, Chapter 57, Room Air Distribution, recommends that “A return inlet affects room air motion only in its immediate vicinity. The intake should be located in the stagnant zone to return the warmest room air during cooling or the coolest room air during heating. The importance of the location depends on the relative size of the stagnant zone, which depends on the type of outlet.”

Also, the return or exhaust grille does not short circuit the supply jet. In fact, if a supply jet is at or above 150 fpm (0.76 m/s) and directed over a return, the jet will either pull air out to the return or exhaust or create a “blanking effect” over the return or exhaust where no air is taken out of the space. If the return or exhaust is placed at the end of the supply jet where the velocity is 150 fpm (0.76 m/s) or less, the air being returned is at or near room temperature and the amount of air being returned is close to 5% of the total air motion in the space.

Terminal Device	Room Load, Btu/h-ft ²	T_{50}/L for Maximum ADPI	Maximum ADPI	For ADPI Greater Than	Range of T_{50}/L
High Sidewall Grilles	80	1.8	68	–	–
	60	1.8	72	70	1.5 to 2.2
	40	1.6	78	70	1.2 to 2.3
	20	1.5	85	80	1.0 to 1.9
	<10	1.4	90	80	0.7 to 2.1
Circular Ceiling Diffusers	80	0.8	76	70	0.7 to 1.3
	60	0.8	83	80	0.7 to 1.2
	40	0.8	88	80	0.5 to 1.5
	20	0.8	93	90	0.7 to 1.3
Sill Grille, Straight Vanes	80	1.7	61	60	1.5 to 1.7
	60	1.7	72	70	1.4 to 1.7
	40	1.3	86	80	1.2 to 1.8
	20	0.9	95	90	0.8 to 1.3
Sill Grille, Spread Vanes	80	0.7	94	90	0.6 to 1.5
	60	0.7	94	80	0.6 to 1.7
	40	0.7	94	–	–
	20	0.7	94	–	–
Ceiling Slot Diffusers (For T_{100}/L)	80	0.3	85	80	0.3 to 0.7
	60	0.3	88	80	0.3 to 0.8
	40	0.3	91	80	0.3 to 1.1
	20	0.3	92	80	0.3 to 1.5
Light Troffer Diffusers	60	2.5	86	80	<3.8
	40	1.0	92	90	<3.0
	20	1.0	95	90	<4.5
Perforated, louvered ceiling diffusers	11 to 50	2.0	96	90	1.4 to 2.7
				80	1.0 to 3.4

Table 2: Air diffusion performance index (ADPI) selection guide (from Table 4, Chapter 57 of the 2011 ASHRAE Handbook—Applications).

High Velocities in Occupied Zone

A system can be designed with proper capacities and air changes but still result in discomfort due to air greater than 50 fpm (0.25 m/s) entering the occupied zone. Designing to avoid the air-distribution problems shown in *Figures 5* and *6* will greatly improve the comfort of a space.

Examples Using Throw Data

The following examples show how the throw data can be used to predict the resulting air motion in a space. In this example, the space is 20 ft × 20 ft with 9 ft (6 m × 6 m with 3 m) ceilings and the required airflow is 950 cfm (448 L/s).

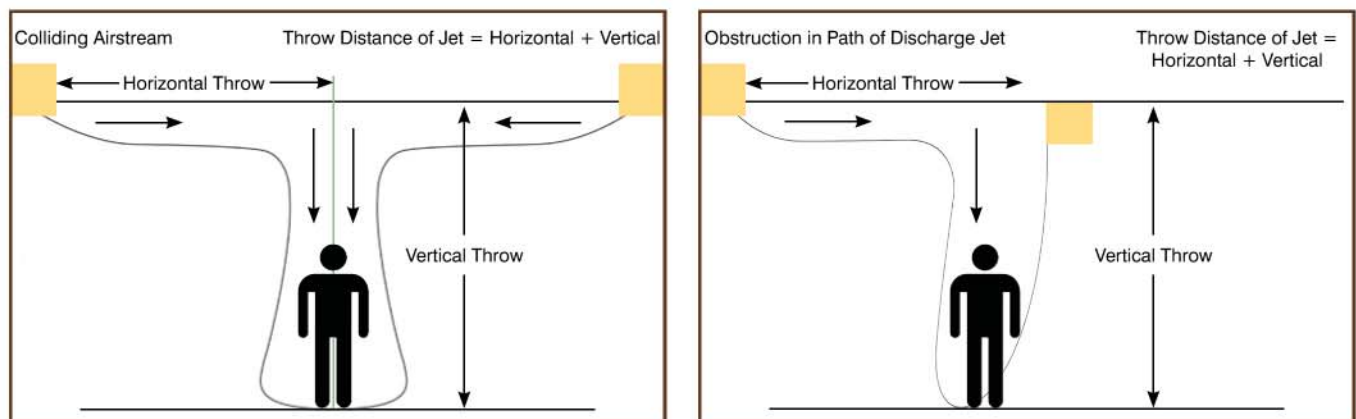

Figure 5 (left): Colliding airstreams can project a high velocity airstream into the occupied zone. This can be predicted by mapping the catalog throw data or the T_{50}/L ratio. **Figure 6 (right):** Obstructions in the airstream such as architectural details and support beams can force the supply jet down into the occupied zone causing occupant discomfort.

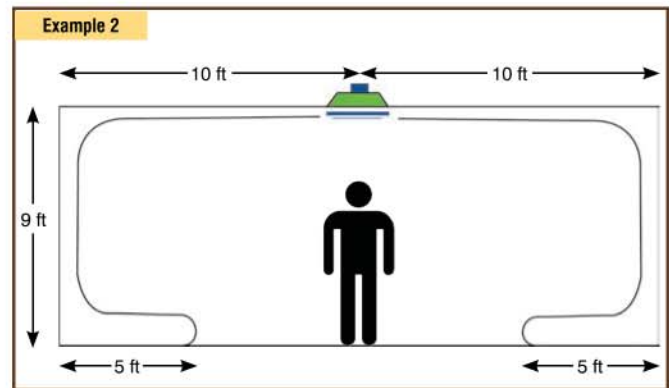
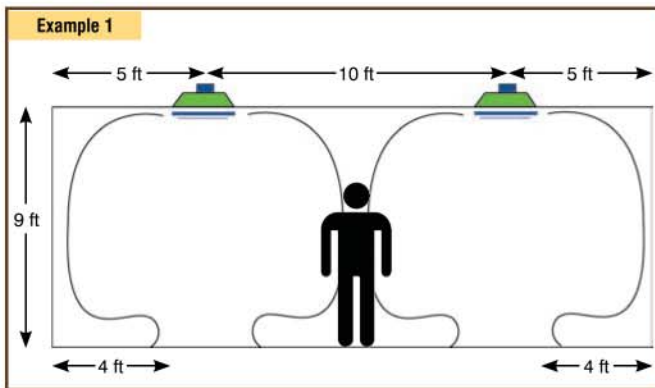

Figure 7 (left): Diffuser Performance. Two louver-faced 15 in. × 15 in. (381 mm × 381 mm) inlets. Each diffuser is 469 cfm (1650 L/s), totaling 938 cfm. Throw data is 18 (50 fpm) and $NC < 20$. Use the T_{50}/L ratio to obtain ADPI range for 90%: 1.4 to 2.7 and T_{50}/L calculation $18/5 = 3.6$. **Figure 8 (right):** Diffuser Performance. One louver-faced 21 in. × 21 in. inlets with four-way discharge. Each diffuser is 919 cfm. Throw data is 24 (50 fpm) and $NC < 20$. Use the T_{50}/L ratio to obtain ADPI range for 90%: 1.4 to 2.7 and T_{50}/L calculation $24/10 = 2.4$.

Example 1

In this example (Figure 7), colliding airstreams will generate a high velocity in the occupied zone. The T_{50}/L calculation shows a value of 3.6, higher than the desired 1.4 to 2.7, indicating a draft in the occupied zone. We also can predict too high a veloc-

ity in the center of the space by mapping out the throws of the outlets.

Example 2

To reduce the room air velocity, one diffuser is selected and placed in the center of the room (Figure 8). The value of T_{50}/L is now 2.4 and within the recommend range to maximize the ADPI value for the space. Although the supply jet does reach the floor and enters the occupied zone, from Figure 2 we know that the ankle region is much more tolerant to higher velocities compared to the neck region.

This selection has eliminated one diffuser compared to Example 1 and the associated costs while providing a higher level of comfort.

Conclusion

Most HVAC designers spend a significant amount of time selecting chillers, air handlers, pumps and cooling towers with the purpose of maintaining occupant thermal comfort in a space. Most conventional air distribution systems in North America are mixed air systems where space comfort is maintained through the induction of air from the occupied zone into the unoccupied zone. The definition of comfort includes maintaining room air velocities below 40 fpm to 50 fpm (0.20 m/s to 0.25 m/s). This is sometimes overlooked by designers, resulting in discomfort to the space occupants caused by excessive air motion.

By using some simple selection techniques such as mapping cataloged throw data and the T_{50}/L method to predict ADPI, designers can select and space outlets to maximize the comfort level in an occupied space. Using these methods also offers the opportunity to reduce the required number of outlets and the associated costs.

References

1. Fisk, W.J. 2002. "How IEQ affects health, productivity." *ASHRAE Journal* 44(5).

PARKER BOILER'S NEW CONDENSING BOILERS!



- 399,000-5,443,000 BTU/INPUT
- UP TO 99.7% EFFICIENCIES
- HEAVY DUTY FIRE TUBE TYPE DESIGN
- ALL STAINLESS STEEL CONDENSING FLUE PASSAGES
- NO CAST REFRACTORY MATERIAL







NEVER A COMPROMISE FOR QUALITY OR SAFETY

PARKER BOILER CO
 5930 Bandini Blvd, Los Angeles, CA 90040
 Ph. (323)727-9800 Fax (323) 722-2848
 www.parkerboiler.com sales@parkerboiler.com

www.info.hotims.com/37990-53

News From Our Members

Trane Supply and Panasonic Provide “Ideas for Life”

Trane Supply and Panasonic have joined together to provide “Ideas for Life” that will positively impact contractors’ business and profit margins as a full line stocking distributor of Panasonic Ductless Air Conditioners and Heat Pumps. Trane Supply, with locations in Jacksonville, Tallahassee, Ocala, North and South Orlando, Daytona Beach, Port St. Lucie, Melbourne, West Palm Beach, Pompano, Miramar and Miami are ready to provide contractors support with advertising, inventory, product, application and service training. Panasonic’s Ductless Technology provides viable solutions for home applications, either in addition to an existing conventional system or simply to cool or heat an uncomfortable spot.

53 years since its establishment, Panasonic Air Conditioning Group has grown into a global company. Through a continuous quest for product innovations, the Group has evolved from manufacturing compressors to providing Comprehensive Air Conditioning solutions. This has earned Panasonic the reputation as the trusted brand for superior quality and reliable products in the industry.

According to Panasonic, “we don't just condition buildings. We condition people. That's because we've thought beyond just Air Conditioning (AC) to something we like to call Human Conditioning (HC). This is the process that guides our technology and system attributes, and, in turn, provides for maximum conditioning solutions for your environment.”

All ECO-i systems utilize highly advanced inverter controlled compressor technology. By varying the rotational speed of the compressor, the inverter control can precisely match the amount of refrigerant being delivered to the needs of each zone. This intelligent approach helps realize excellent efficiencies during partial-load conditions. This allows all occupants to enjoy consistent room temperature, regardless of any increases or decreases in the heat load during the day. ECO-i quite simply knows what is needed, and when it is needed throughout the day. And even better, it does so with energy efficiency in mind. Panasonic manufactures their own compressors and are the largest compressor manufacturer in the world. Panasonic offers 7 years warranty on the compressor and 5 years on parts.

“Trane Supply and Panasonic are recruiting dealers now so that we can add your businesses to our website and help position you as the ductless leader in your respective markets,” stated Trane Supply Sales Manager Andy Taylor. “Contact your local Trane Supply location or Account Manager for more information.”

The Inspectors Corner

ORANGE COUNTY'S TAKE ON R-22 DRY SHIP UNITS

Recently, there have been numerous calls regarding R-22 dry units, asking if Orange County will allow them to be installed per code or not. As we all know, in 2009 the EPA ordered the A/C equipment manufactures to stop manufacturing equipment with R-22. In the middle of 2010, some manufactures began producing R-22 equipment that did not contain R-22 refrigerant. These dry shipped units exploited a loophole in the original EPA ruling of 2009.

Another frequently asked question is, “do dry shipped units meet the 2010 Florida Energy Conservation Code”? The FECC-101.4.7 gives you 4 ways to meet the mix matched equipment requirements.

1. AHRI data.
2. Accredited Laboratory
3. Manufactures letter
4. Letter from a registered P.E of the State of Florida.

The FECC-101.4.7 also states to refer to section 403.6.2.1.1 which states, “where components such as indoor or outdoor coils from different manufactures are used, a Florida Registered Engineer shall specify component efficiencies whose combined efficiency meets the minimum equipment efficiency requirements”. To answer this question safely and the best of my ability, it is the intent of the EPA ruling to phase out R-22.

In November 2010 AHRI decided to return R-22 products to the scope of the AHRI Certification Program, there by requiring dry R-22 models to continue to be listed in the AHIR Directory of Certified Product Performance. The R-22 models certified by AHRI and displayed in the AHRI Directory are High Sale Volume Tested Combinations (HSVTC) only with NO MIX MATCH coil listings. So, my advice would be, before you purchase or install one of these (DRY SHIPPED R-22 UNITS) do your home work and see if it can be approved first BY the Mix Matched requirements.

Gene Price
Chief Mechanical Inspector
Growth Management Department
Division of Building Safety

Instructors Needed

ACCA/CF Apprenticeship Program

The ACCA of Central Florida is seeking full-time instructors for all levels of its HVAC Mechanic program, which is a full 3-year indentured apprentice program, Florida State Certified through the Florida Bureau of Apprenticeship. This program curriculum was handpicked by the ACCA of Central Florida Apprenticeship Committee for the local contractors to train their employees.

A certificate of competency will be issued for each full year of completion. Upon completion of the third program year, the apprentice will receive a final certificate of completion from the State of Florida Department of Education Bureau of Apprenticeship, and he/she will also be certified by the Air Conditioning Contractors Association of Central Florida. All third year apprentices will be required to take a national AHRI Industry Competency Exam administered by an outside source at the end of the course.

During the first year, the apprentice learns basic knowledge of Air Conditioning fundamentals, such as, superheat and subcooling, matter and energy and basic electricity, blueprint reading, tools and their uses, system components and how they relate to each other in the refrigeration system.

During the second year, the apprentice will obtain a better knowledge of superheat and subcooling as they relate to air flow, refrigerant charge, restrictions in the refrigerant circuit, non condensables, valve problems and load issues among other problems. A special emphasis will be put on these concepts because they are so misunderstood in our trade.

And in the third, apprentices will delve into electrical installations and troubleshooting in detail. They will gain knowledge about motors and motor controls, electric control valves, control devices and control circuits and diagrams. Apprentices will learn proper start-up and check out procedures. They will also learn more about refrigeration specialties like driers, sight glasses, receivers, relief valves, vibration absorbers and others.

This is a paid position through Orange Country School District. All applicants will be subject to their hiring procedures, including a background check.

If you are interested in more information about the Apprenticeship Program, visit ACCA/CF's website at www.accacf.org. To apply for a position, contact Gary MacLeod at 407-905-2074 or Gary.MacLeod@ocps.net.

Meet The Board

Officers

Chairman - Andrew F. Brunkala, Jr.

Air Tech Of Central Florida
813 Waterway Place
Longwood, FL 32750
andy@airtechofcentralflorida.com
407-696-9876

President - Scott Hudson

Rinaldi's Air Conditioning Service
15264 E. Colonial Dr.
Orlando, FL 32828
scott@rinaldis.com
407-275-0705

Vice President - Rod Facemyer

Facemyer A/C & Heating, Inc.
3805 St. Johns Parkway
Sanford, FL 32771
rod@facemyerac.com
407-322-7455

Secretary/Treasurer - Rob Kulp

Energy Air, Inc.
5401 Energy Air Court
Orlando, FL 32810
rkulp@energyair.com
407-886-3729

Directors

Brian Hastings

4 Seasons A/C & Heating
P.O. Box 607903
Orlando, FL 32860-7903
bhastings@4seasonsair.net
407-295-9231

Pat Ambrose

Ambrose Air
448 West Landstreet Road
Orlando, FL 32824
pat@ambroseair.com
407-857-0889

Mark Wesson

Wesson Air
156 Baywood Ave.
Longwood, FL 32750
mark@wessonair.com
407-831-5061

John Green, Jr.

Green's Energy Service
186 North Goldenrod Road
Orlando, FL 32805
jgreen@greensenergy.com
407-282-5000, x113

Tom Nixon

Pro-Tech A/C
2425 Silver Star Rd.
Orlando, FL 32804
407-291-1644

Apprenticeship Program Coordinator

Gary MacLeod

Westside Tech
955 East Story Road
Winter Garden, FL 34787
gary.macleod@ocps.net
407-905-2074

Executive Director - Paula Keyes

Paula Keyes & Associates
P.O. Box 160910
Altamonte Springs, FL 32716
Paula@accacf.org
407-260-2206 (ACCA/CF number)
407-810-0271 (cell)

BAKER DISTRIBUTING'S
CONTRACTOR ASSIST



Baker Distributing Company strives to make life as an HVAC professional easier and faster. The HVAC Contractor Assist provides access to product information and easy to use tools while on the go.



GET IT TODAY!
Available for iPhone & Android

We Have An App And A Mobile Site For That!

- Instantly know product availability at Baker Distributing stores near you
- Receive push notifications of special offers and promotions
- Scan QR & UPC bar codes for fast product lookups
- See turn by turn driving directions, through map integration to our locations
- Light up attics, closets and basements while you work with the built in flashlight

Distributing Company

Superior Service...Solid Solutions

m.bakerdist.com
mybakeronline.com
bakerdist.com

Education Programs

Johnstone Supply & ACCA/CF Present



MOTORS OVERVIEW

New Technology • Contractor Benefits • Troubleshooting

Tuesday May 14, 2013

5:30 - 7:30pm

Johnstone Supply Orlando

1651 South Rio Grande

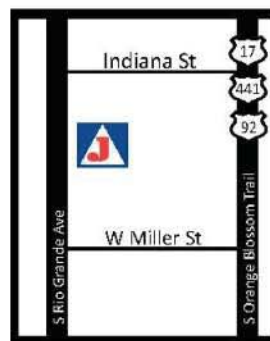

Cost

\$15 ACCA/CF Members
\$25 Non-Members

Dinner

Provided by
Johnstone Supply

Instructor

Dennis Campbell Jr.



Motor Corp

Topics Include

MULTI HORSEPOWER MOTORS

- what makes a motor multi-horsepower vs. multi-speed
- how the RESCUE MULTI-HORSE POWER motor benefits the contractor

ECOTECH

- Upgrade the homeowners current PSC system to ECM technology
- the Drop-in ECM replacement for a PSC
- generate more revenue while saving the homeowner money on energy cost

SELECT OEM ECM REPLACEMENT for constant Torque motors like X13 and SelecTech

ECM TROUBLESHOOTING

- How to determine if the electronic module or the motor is bad



Please RSVP
to Attend

Limited to 40 Attendees

Email: Jeanne@accacf.org

Phone: 407-260-2206

Online: www.accacf.org



Sponsored by



The Ware Group



Wright, Fulford, Moorhead & Brown, P.A.

A Construction Law Firm

Practice Areas:

- Lien Claims
- Contract Review/Preparation
- Construction & Design Defect Claims
- Disruption & Delay Claims
- Administrative and Construction Licensing
- Landlord/Tenant Build-Out Disputes
- Bond Claims
- Contract Disputes
- Bid Protest Proceedings
- Environmental Claims
- Construction Related Professional Liability

CONTACT: MARK T. SNELSON, ESQ. / msnelson@wfmblaw.com

Mark Snelson is a Partner in the law firm Wright, Fulford, Moorhead & Brown, P.A., in Altamonte Springs, Florida. The firm is an ACCA/CF Member and its entire practice is devoted to construction law. If you have any questions about any legal issue affecting your business, Mark can be reached through the contact information below.



407-425-0234 / 800-327-0234

505 Maitland Avenue, Suite 1000, Altamonte Springs, FL 32701

www.wfmblaw.com

May MEETING

*Topic: EnergyGauge USA Residential Software
Demonstration*

Speaker: Jeff Sonne, Florida Solar Energy Center

Date/Time: May 16, 2013 11:30 a.m. - 1:30 p.m.

Location: Crowne Plaza Hotel, Orlando

For more information, visit our website at www.accacf.org

Associate Members

Atlas Sales and Rental, Inc., Orlando

Baker Distribution, Jacksonville

Blacks Supply, Inc., Orlando

Bowen, Miclette & Britt Insurance, Maitland

Carrier Enterprise, Orlando

Con-Air Industries, Orlando

Florida Cooling Supply, Jacksonville

Insurance Office of America, Altamonte Springs

Johnstone Supply, Orlando

Lassiter-Ware Insurance, Maitland

Lennox Industries, Orlando

Progress Energy, Lake Mary

Stanley Steemer, Apopka

Trane Company, Orlando

Tropic Supply, Orlando

Virtual Fleet Supervisor, Orlando

Wright, Fulford, Moorhead & Brown, P.A., Altamonte Springs